

3. Installation guideline

These general installation instructions apply to buried PE-HD pipes according to DIN 8074/8075. They are complementary to existing specific standards and guidelines of DIN, DWA, DVGW, DIN CERTCO, DVS and KRV. Especially, for the jointing techniques, it is necessary also to adhere to the separate instructions issued by each of the different joint manufacturers.

PE-HD pipes and pipelines shall be processed and laid by well-trained specialist staff only. Installation work for gas and potable water supply shall be performed only by pipeline installation companies having a DVGW certificate according to DVGW Worksheet GW 301 – DVGW procedure for the certification of pipeline companies.

Construction work must be performed by installers having completed a training course according to DVGW Worksheet GW 330 – Welding of PE-HD pipes and pipeline components for gas and water mains; teaching and test plan. The activities need to be supervised by welding engineers according to the DVGW Worksheet GW 331 – Weld supervision for welding on PE pipelines for gas and water supply; teaching and test plan. The rules of accident prevention of the employers insurance liability company shall be observed during installation. The road traffic regulations are of special importance for any work within traffic zones; the guidelines for safety measures at roadworks sites shall be adhered to.

The limits of use and performance of each product shall be observed.

3.1 Handling

PE-HD plastic pipes are transported in the form of straight lengths, coiled bundles or reels. They shall be properly handled, loaded and unloaded.

Upon delivery or just before the installation, an optical inspection of the pipe shall be carried out according to DVGW G 472, W 400-2, or DIN EN 805. Also, the information printed on the pipe shall be checked and the jointing zones shall be cleaned. Damaged parts will be discarded. Cuts can be made with a fine-toothed saw or a plastic pipe cutter. Guided saws, e.g. mitre boxes, allow cuts perpendicular to the pipe axis. Burrs and irregularities along the parting planes shall be removed with a suitable tool, e.g. a blade or scraper knife. The pipe ends need to be treated according to the jointing technique.

Dirt or incrustations on the inner faces and damages in general shall be prevented. Therefore, the end caps shall be removed only when the pipe components are installed.

Pipes shall not be dragged along ground or floors. Scoring, scratches or surface abrasions up to 10% of the minimum

wall thickness in PE80 and PE100 pipes are tolerable. Pipes with more severe damage are not allowed to be installed (DVGW Worksheet W 400-2/September 2004). Also, lasting deformation of the pipes must be prevented. The storage area should be level and free of stones or sharp-edged objects.

Black PE-HD pipes are sufficiently protected from UV radiation due to their very nature (increased carbon black content in the material). They remain safe even after a longer time/several years of storage in the open air.

Coloured PE-HD pipes (e.g. yellow orange, royal blue) must be subjected to a usability check if exposed to radiation of 7.0GJ/m², which is equivalent to two years of non-protected storage with direct sunlight exposure in Germany. The manufacturer can validate and release the pipes for further use.

The pipes shall be protected from contact with substances that are detrimental to PE (→ Technical Information, p. 61 et seq.).

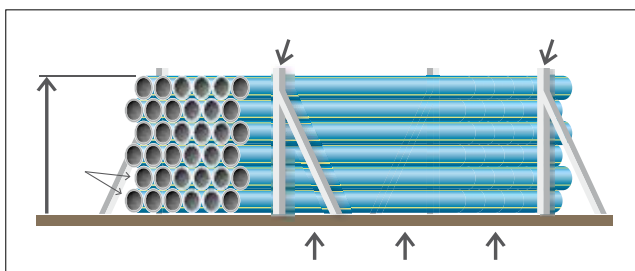

6.18 Correct storage of GEROfit®REX straight pipes without wooden framework

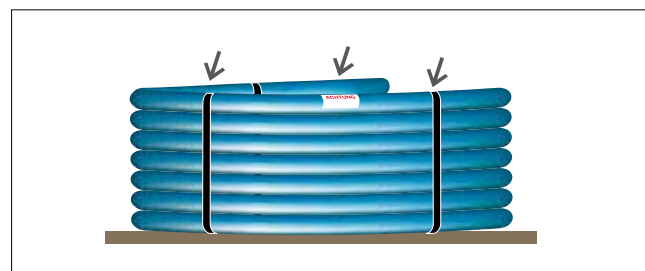

6.19 Correct storage of GEROfit®REX pipe coils

Product-specific instructions

PE pipes in straight lengths

During transport, handling and storage, straight pipes should be supported substantially along their entire length and secured from rolling apart. Furthermore, appropriate retainers will prevent non-palletised pipes from rolling to the sides, for which purpose the pipe stack shall be arranged in straight and staggered layers. The maximum allowable stack height is 1.5 m (SDR classes ≥ 26 minus 0.5 m).

! Thin-walled pipes of the classes SDR 21 to 33 shall be protected from direct sunlight (e.g. with white tarpaulin or fleece) to mitigate the risks of deflection and deformation.

PE-pipes in coils

Coiled pipe bundles shall be stored in horizontal position or in suitable racks. The holding straps or bands shall not be removed until immediately before installation. The information labelled on the coils shall be adhered to.

PE pipes wound on reels

Reels (drums) – especially the Gerodur large-reel system – shall be handled in compliance with the safety and handling instructions attached to them.

Improper handling of reels presents a risk to human health and equipment integrity. For **loading and unloading with a crane** it is therefore necessary to use appropriate spreader bars preventing any damage to the reel and pipe.

If **fork lift trucks** are used, they need to be equipped with specific attachments for reels.

Reels are not allowed to be stacked in storage. They shall be stored in vertical position and secured from rolling. Advantageously, storage areas should have a hard level surface.

Thermal expansion/contraction needs to be taken into account for cutting and laying the pipes. A rise in temperature will cause an increase in the length of the pipe. A drop in temperature causes a PE pipe to shorten by 0.2 mm per metre and K (→ Technical Information, p. 46).

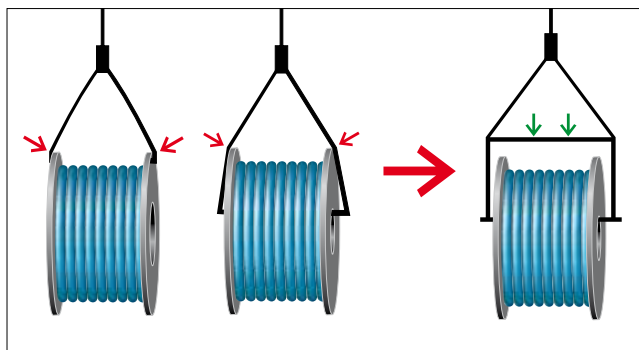

6.20 Loading and unloading of reels with a crane

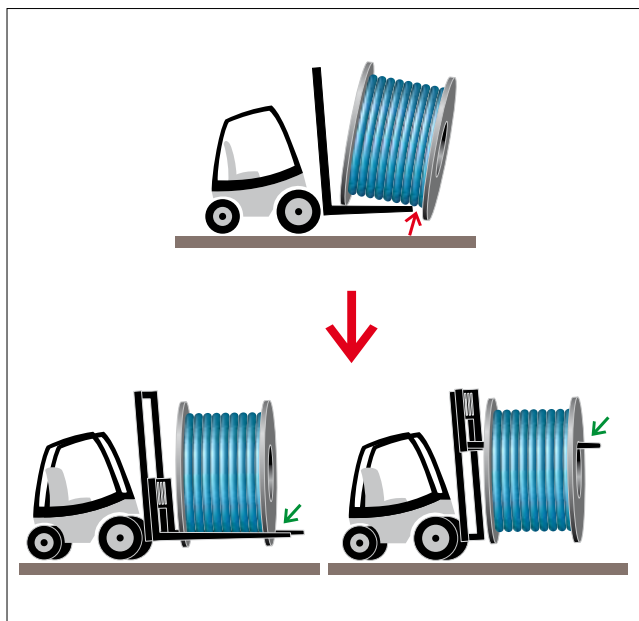

6.21 Handling of reels with a fork lift truck

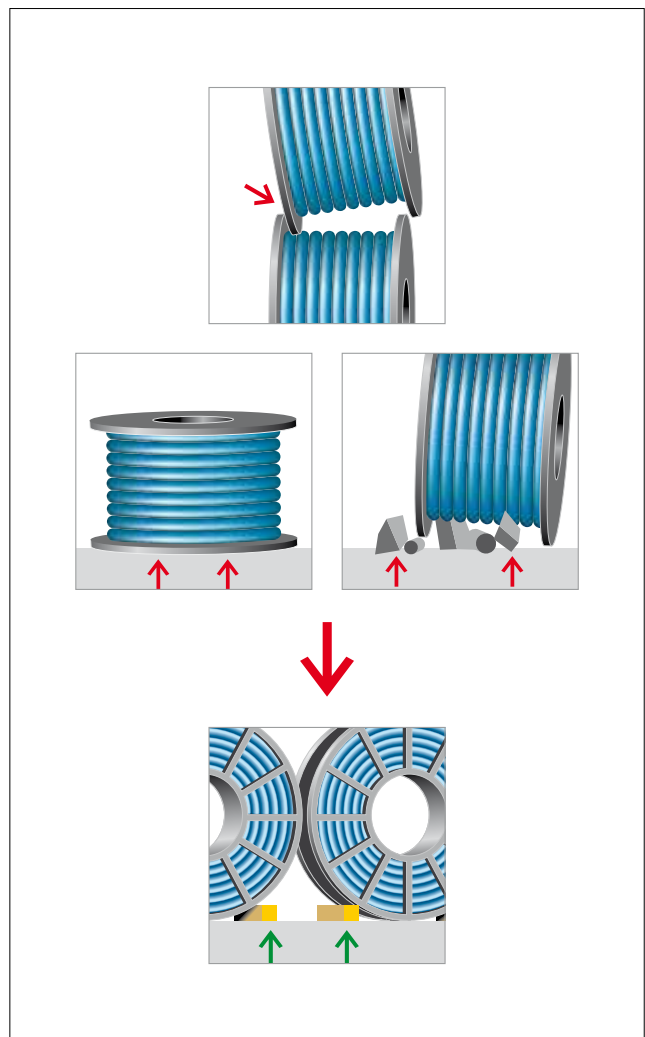

6.22 Correct storage of large-size reels

Unwinding

There are several ways how to uncoil pipes. In general, pipes having an outside diameter up to 63 mm are uncoiled in a vertical position. It is important to restrain the pipe ends when removing the holding straps or bands; otherwise, the pipe end might uncoil with extreme whipping force, especially in case of larger pipe diameters. Therefore, special care is required at this point (danger of accident!). It is wise to use an uncoiling aid. Coiled pipes lying on a wooden or steel carousel can be unwound in a straight line either by hand or via a slowly operating vehicle. Sharp bends (kinks) or spiral unwinding must be prevented.

During uncoiling, it is important to bear in mind that the degree of flexibility of PE pipes depends on ambient temperature. In case of near-frost temperatures pipes with a diameter of 75 mm or higher should, where possible, be warmed up while still in coil, e.g. with hot steam (max. 100°C).

For unwinding pipes on the construction site, a suitable reel handling vehicle or other appropriate equipment should be used (e.g. transporters by BAGELA Baumaschinen GmbH & Co. KG).

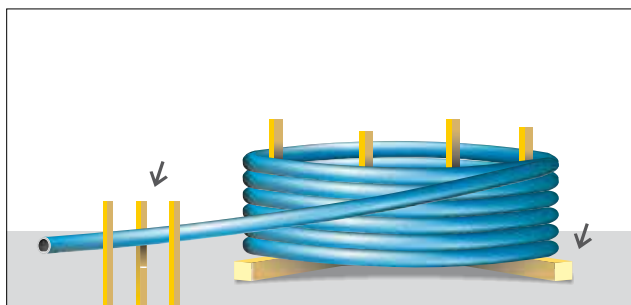

6.23 Carousel-style decoiler

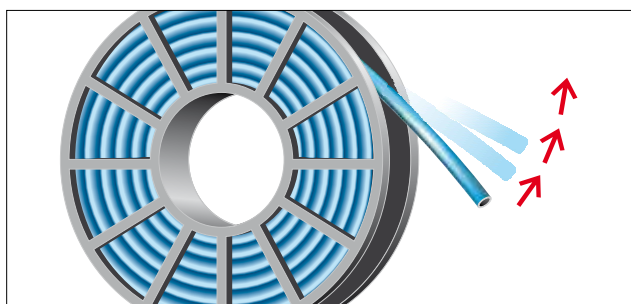

6.24 Caution: Whipping pipe end after removal of straps

Processing

- GEROfit®REx protection jacket pipes are weldable by butt fusion after removal of the additive protection layer and permeation barrier (→ jointing technologies, p. 209 et seq.).
- For welding with fittings, electrofusion fittings (→ jointing technologies, p. 214 et seq.), saddles, standard pipes, PE multilayer pipes with integrated protective layers and jacketed pipes of other manufacturers, it is necessary to remove the protection jacket and the diffusion barrier in the welding area (→ handling of jacket peelers, p. 218 et seq.). In specific project cases, jacket removal can be done in the factory by Gerodur (to customer specifications). For diffusion-proof gas or water transport, however, it is necessary, whether in open or in closed construction, to restore suitable diffusion protection all around the pipe.

! Missing or non-flush or non diffusion-proof outside protection may cause damage to the core pipe or permeation of harmful substances into the pipe. In closed construction, it is possible to "slide" the protection jacket onto the core pipe.

- Butt fusion welding requires appropriate clamp sizes → table 6.27, p. 204
- Pulling heads shall be long enough to provide appropriate protection for the jacket. The maximum allowable tensile forces (→ Technical information, p. 59) shall not be exceeded to avoid lasting damage to the pipeline.



6.25 Pulling head put on the jacketed pipe (incl. jacket thickness)



6.26 Gerodur service: provision of project-specific clamps for butt fusion (Widos) – delivery in robust heavy-duty box

- The pull-in operation inclusive of its parameters (tensile forces) shall be reported.
- The bending radius shall not fall below the allowable limit (→ Technical information, p. 58).
- It is not technologically possible to install GEROfit®REx according to the close-fit method.

Dedicated special clamps for welding machines are available from Gerodur. → Accessories, p. 309.

Core pipe according to DIN 8074 DN/OD [mm]	Clamp size for GEROfit®REx protection jacket pipes [mm]
25	26.6
32	34.4
40	42.4
50	52.4
63	65.7
75	78.0
90	93.1
110	113.6
125	128.9
140	144.2
160	164.7
180	186.5
200	206.6
225	231.8
250	256.9
280	288.7
315	323.9
355	364.2
400	412.4
450	462.7
500	513.0
560	573.4
630	643.8
Subject to production tolerances	

6.27 Core pipe diameters of GEROfit®REx protection jacket pipes with the related clamp sizes.

3.2 Installation

Trenching

Construction of pipe trench

The pipe trench shall be constructed according to DIN 4124. The backfill soil shall be assessed according to ZTV A-StB and DIN 18196. Installation work in public spaces is governed by DIN 1998.

Application	Potable water
Recommended height zone h in built-up areas	0.9 m to 1.8 m, depending on climate and soil conditions

6.28 Application-specific installation depths according to DVGW W 400-1

DN/OD [mm]	Minimum trench width $b (d_n + x)$ [m]			
	Sheeted trench		Non-sheeted (sloped) trench	
	Typical	Bracing	$\beta > 60^\circ$	$\beta \leq 60^\circ$
≤ 400	$d_n + 0.4$	$d_n + 0.7$	$d_n + 0.4$	$d_n + 0.4$
> 400	$d_n + 0.7$	$d_n + 0.7$	$d_n + 0.7$	$d_n + 0.4$

6.29 Trench width as a function of pipe size and slope angle according to DIN 4124

- The pull-in operation inclusive of its parameters (tensile forces) shall be reported.
- The bending radius shall not fall below the allowable limit (→ Technical information, p. 58).
- It is not technologically possible to install GEROfit®REx according to the close-fit method.

Dedicated special clamps for welding machines are available from Gerodur. → Accessories, p. 309.

Core pipe according to DIN 8074 DN/OD [mm]	Clamp size for GEROfit®REx protection jacket pipes [mm]
25	26.6
32	34.4
40	42.4
50	52.4
63	65.7
75	78.0
90	93.1
110	113.6
125	128.9
140	144.2
160	164.7
180	186.5
200	206.6
225	231.8
250	256.9
280	288.7
315	323.9
355	364.2
400	412.4
450	462.7
500	513.0
560	573.4
630	643.8
Subject to production tolerances	

6.27 Core pipe diameters of GEROfit®REx protection jacket pipes with the related clamp sizes.

3.2 Installation

Trenching

Construction of pipe trench

The pipe trench shall be constructed according to DIN 4124. The backfill soil shall be assessed according to ZTV A-StB and DIN 18196. Installation work in public spaces is governed by DIN 1998.

Application	Potable water
Recommended height zone h in built-up areas	0.9 m to 1.8 m, depending on climate and soil conditions

6.28 Application-specific installation depths according to DVGW W 400-1

DN/OD [mm]	Minimum trench width $b (d_n + x)$ [m]			
	Sheeted trench		Non-sheeted (sloped) trench	
	Typical	Bracing	$\beta > 60^\circ$	$\beta \leq 60^\circ$
≤ 400	$d_n + 0.4$	$d_n + 0.7$	$d_n + 0.4$	$d_n + 0.4$
> 400	$d_n + 0.7$	$d_n + 0.7$	$d_n + 0.7$	$d_n + 0.4$

6.29 Trench width as a function of pipe size and slope angle according to DIN 4124

The minimum trench width b shall be the higher of the values depending on the nominal diameter (DN/OD) and the trench depth ($h + d_n$).

For the values for $d_n + x$, $0.5x$ is equivalent to the minimum working space between pipe and trench wall or trench sheeting according to DIN 4124. The trench bottom shall be constructed so as to evenly support the pipeline.

Bedding and backfill

GEROfit®REX protection jacket pipes with a core pipe made of PE100-RC are suitable for installations without sand bedding due to their high resistance to slow crack growth as proven by an independent accredited testing institute. This implies less work and cost for excavation and replacement of in-situ ground with bedding sand according to DIN EN 805 (transport and landfill).

The pipe characteristics require no grain size restrictions for bedding and backfill materials. Installation work in the public space (e.g. roadworks) must be in compliance with further requirements, standards and guidelines:

- DIN V ENV 1046
- DIN 4124
- DIN 18123
- DIN 18196
- DIN EN 805
- DIN EN ISO 14688
- ZTV A-StB
- ZTV E-StB

DN/OD...nominal size as referred to the outside diameter [mm]

d_n nominal outside diameter [m]

β slope angle of the non-sheeted trench [°]

b minimum trench width [m]

h height zone [m]

The installation of water pipes is governed by DIN EN 805 and DVGW W 400-2.

Depth of backfill cover $h + d_n$ [m]	Minimum trench width b [m]	
≤ 1.75	sloped 0.6	sheeted 0.7
> 1.75 to ≤ 4.0	0.8	
> 4.0	1.0	

6.30 Trench width as a function of pipe diameter and backfill cover according to DIN 4124

The backfill cover shall be selected so as to ensure the pipeline is buried below the frost line, depending on climate and soil conditions. The recommended depth of cover for agricultural lands is no less than 1.2 m.

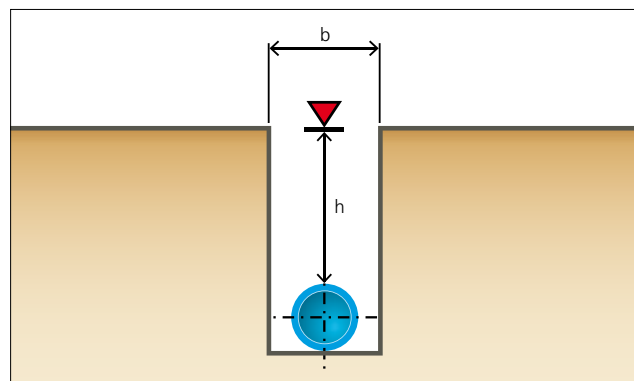

6.31 Pipe trench – open construction

Low-dig and no-dig (trenchless) installation

Trenchless installation techniques cause higher stress and loads than the conventional open-trench construction of a pipeline. GEROfit®REX pipelines meet all requirements for sandless and trenchless installations on a properly tested and verified basis.

Installers must comply with DVGW W 400-2 worksheets and the DVGW method instructions for the different trenchless laying techniques to maintain constant quality standards:

- Relining (rehabilitation) according to DVGW GW 320
- Controllable horizontal directional drilling according to DVGW GW 321
- No-dig replacement using pushing or pulling procedures according to DVGW GW 322
- No-dig renewal by pipe bursting procedure according to DVGW GW 323
- Milling and ploughing procedures according to DVGW GW 324
- No-dig construction types for gas and water connection lines according to DVGW GW 325 (non-finalised draft)

Trenchless pipeline installation operations require extensive planning and design. It is necessary to conduct a preliminary assessment of the existing piping structures or subsoil conditions to select then the installation procedure, the appropriate pipe, the pipe joint and the other parameters.

Pipeline construction companies qualified according to DVGW GW 301 need the additional qualification R (rehabilitation) or GN (no-dig installation). A qualification according to DVGW GW 302 is sufficient for companies performing trenchless procedures without disruption or start-up of service and without connection or reconnection work during continued service.

Trenchless pipe installation shall be recorded in a traceable documentation (including material certificates, test report with tensile forces, leak testing, CCTV inspection and other relevant processes).

Introduction of GEROfit® REx protection jacket pipes

The dimensions of the access pit vary according to the laying method. Generally, the bending radius of the pipe shall not fall below the respective allowable minimum – but short-term deviation is considered not to be critical. Kinking of the pipe must be prevented.

The length of the access pit [m] results from:

1.31

$$L = \sqrt{H \times (4 \times R - H)}$$

For smaller pipe diameters, the pit dimensions can be reduced by lifting the pipe according to the following formula:

1.32

$$L^* = \sqrt{H \times (2 \times R - H)}$$

- L.....length of access pit [m]
- L*.....reduced length of access pit [m]
- H.....pipe bottom depth [m]
- R.....allowable bending radius [m]
- WP.....turning point
- WP*possible turning point at smaller pipe dimensions (e.g. up to DN 300)
- d_nnominal outside diameter [mm]

Allowable bending radius: $R = 20 \times d_n$ at 20°C
 → Technical information, p. 58

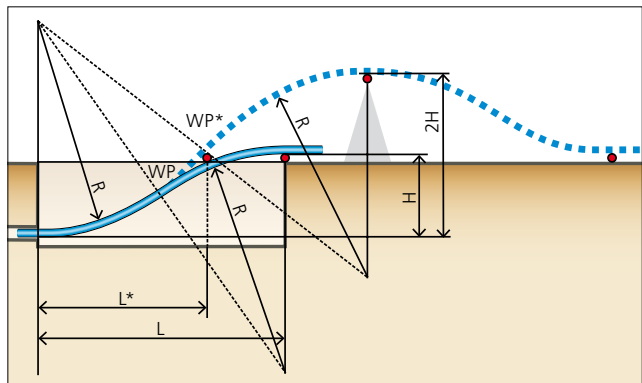

6.32 Determination of introduction lengths for GEROfit® REx protection jacket pipe

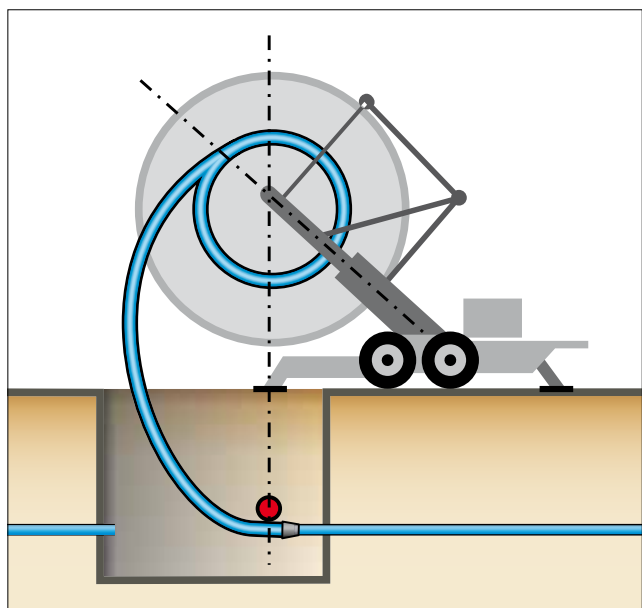

6.33 Introduction of GEROfit® REx protection jacket pipe from coil or large-size reel

Milling and ploughing (DVGW GW 324)

These installation methods are typically used in rural areas and outside traffic zones. In both techniques it is important to adhere to the allowable bending radii and tensile forces of the piping system being laid (DVGW requirements).

Milling (narrow trenching) is an open-cut method for mechanically cutting a narrow trench into ground while placing the GEROfit® REx pipe at the same time onto the bottom of the trench. In most cases, the process produces a non man-entry trench and uses a laying box as temporary sheeting. The

trench needs no sand bedding and can thus be mechanically backfilled, and compacted, with compactable material removed during the cutting process.

Ploughing is a minimum-dig method for displacing soft ground with a plough blade and placing the GEROfit® REx piping via a laying box onto the bottom of the furrow thus produced. The method can achieve installation rates of up to four kilometres per day, depending on soil class, pipe diameter, installation depth and equipment used.

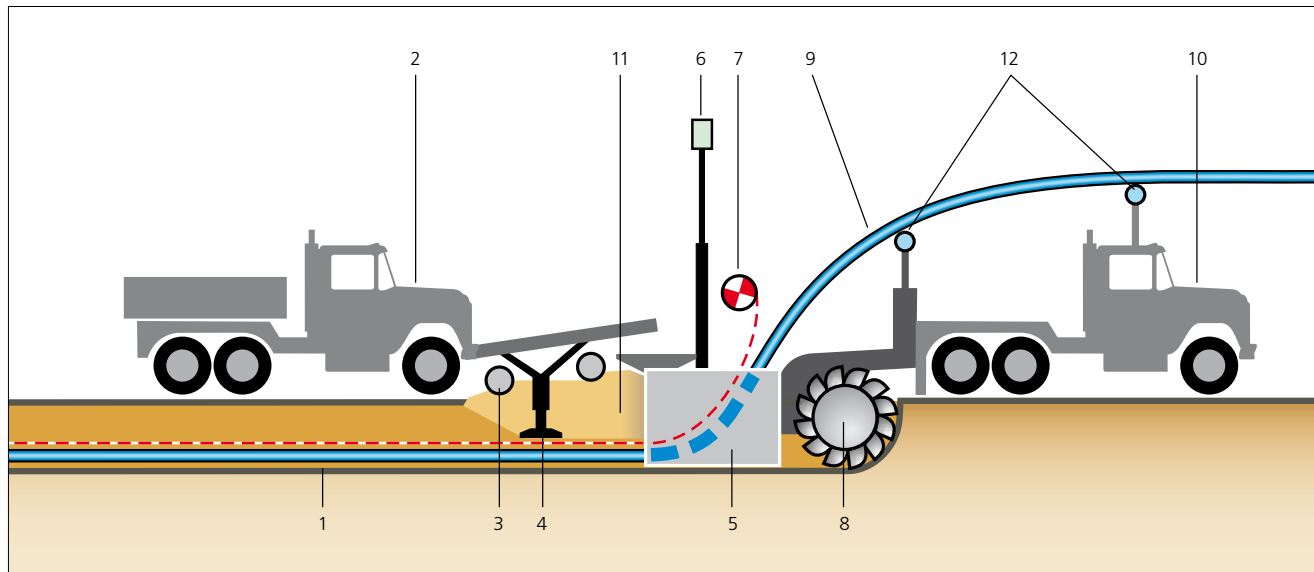

6.34 Narrow trenching | 1 trench bottom | 2 backfill and compaction unit | 3 axial screw conveyors | 4 compactor | 5 laying box | 6 laser receiver | 7 utility marking tape | 8 milling disc or cutter chain | 9 GEROfit® Rex jacket pipe | 10 trenching and laying unit | 11 extracted material (spoil) | 12 piping guides

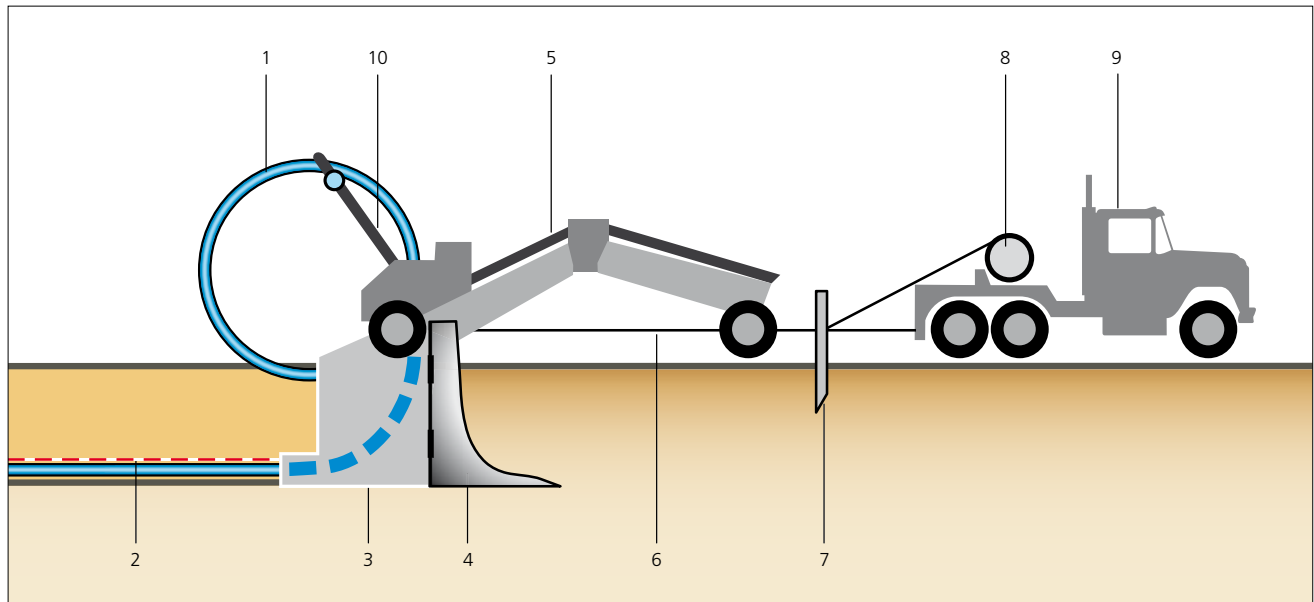

6.35 Ploughing | 1 GEROfit® Rex jacket pipe | 2 utility marking tape | 3 laying box | 4 plough blade | 5 plough | 6 pulling cable | 7 support | 8 cable winch | 9 winch truck | 10 piping guide

Soil displacement method

The soil displacement technique is an economical and proven procedure best suited for the construction of house laterals and used worldwide for three decades already. An air-operated displacement hammer, also known as „rocket“, is driven through the ground to create an underground void into which the GEROfit® REx protection jacket pipes are introduced. There is no need to dig up or destroy existing surface structures or spaces like yards, gardens or traffic zones. Traffic will not be disrupted, and time and money can be saved for larger construction projects.

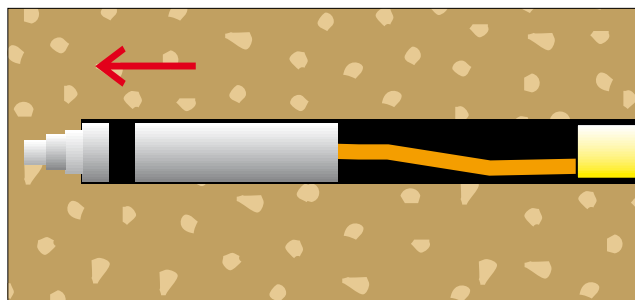

6.36 Soil displacement

Directional drilling method

The installation of a new pipeline according to the directional drilling method is performed in three consecutive steps. The first step is the localisation-controlled boring of a continuous pilot hole, which defines the pipe route. Then the pilot hole is enlarged to the diameter required for the introduction of the GEROfit® REx protection jacket pipe (reaming). In the third step, the butt fusion-jointed thrust-resistant piping is introduced into the enlarged hole. The execution of the works must be supervised by an engineer according to DVGW GW 329. The buckling strength of the pipeline must be higher than the maximum pressure of the drilling fluid.

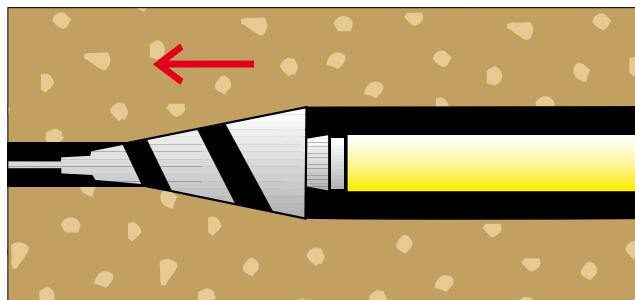

6.37 Directional drilling

Pipe bursting method

Pipe bursting is a structural renovation method for the renewal of an existing pipeline along its existing route. The old pipe is destroyed by the bursting head and the remaining pipe debris are pressed into the surrounding ground. The butt fusion-jointed thrust-resistant GEROfit® REx piping is installed in the void thus created. The external bead of the welded joint must be removed for this purpose. The new pipe can have a larger diameter than the old one. The newly installed pipeline must be dimensioned to withstand the internal pressure or buckling pressure. → Technical information, p. 56

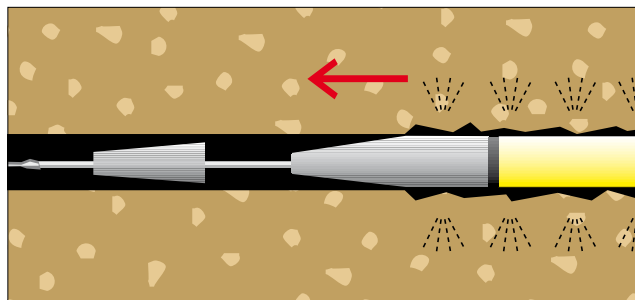

6.38 Pipe bursting

Relining method

The relining method with annular space uses the existing pipe as a host pipe into which the butt fusion-jointed thrust-resistant GEROfit® REx piping of reduced cross-section is introduced with the help of an installation device. The external and internal beads of the weld joint can be removed prior to installation. The annulus between the host pipe and the GEROfit® REx pipe can be filled afterwards. The entire host pipe must meet the structural strength requirements. The liner pipe must be dimensioned to withstand the internal pressure or buckling pressure. → Technical information, p. 56

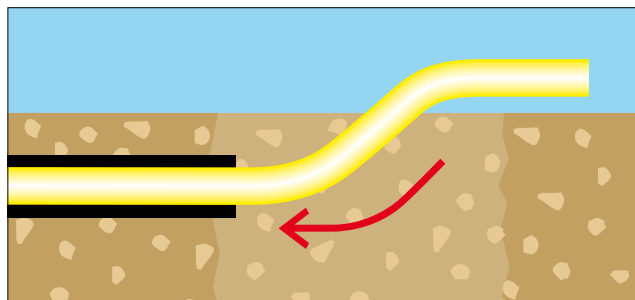

6.39 Relining

The allowable bending radii and tensile forces must be adhered to in all methods. → Technical information, p. 58 et seq.

3.3 Jointing technologies

GEROfit®REX protection jacket pipes can be joined by means of appropriate jointing technologies according to the generally accepted engineering rules known for PE-HD pipes to form a pressure-sealed leak-free piping system.

The following table shows some of the common and recommended technologies for thrust-resistant pipe end-to-end and pipe-to-fitting joints according to current standards and guidelines.

Jointing method	Friction-locked/ detachable	Firmly bonded
Clamped, bolted, socket or pressed joints	✓	
Flange joints	✓	
Butt fusion		✓
Electrofusion (fittings)		✓

6.40 Categories of jointing techniques

Welding shall meet the following requirements for PE-HD pipes:

- Qualification of welders according to DVGW GW 330 or DVS 2212-1
- Execution of works according to DVS 2207-1 and use of equipment according to DVS 2208-1
- Supervision of welding operations according to DVGW GW 331 or DVS 2212-1 (Supplement 1)

Butt fusion welding (HS)

The fusion ends of the pipes or pipe components to be joined are matched with a heater plate (initial bead-up phase), then heated to welding temperature at reduced pressure (heat-soak phase) and, after removal of the heater plate (changeover phase), joined under pressure (fusion jointing). The manufacturer's information and instructions shall be observed.

GEROfit®REX jacket pipes are approved for butt fusion welding under the guidelines of the German Welding Society (DVS), which have general acceptance on the European level.

Basic conditions

The welding area shall be shielded from unfavourable weather (e.g. humidity, wind, excessive sunlight, or temperatures below 0°C). If the pipe accumulates local heat from direct sunlight, the weld area should be covered early enough to bring the temperature down.

The mating fusion surfaces of the components to be welded must not be damaged and must be free of contamination (e.g. dirt, grease, chips). The fusion surfaces shall be cleaned directly before welding. As pipes may show ovalities after storage, it may be necessary to restore the shape of the pipe ends, e.g. by

When using mechanical jointing systems – clamped, bolted, pressed or socket joints – or welding fittings, it is generally necessary to remove the protection jacket from the core pipe in the jointing zone (peeling). In this case, the protection of the diffusion barrier layer needs to be restored after jointing. Approved mechanical jointing systems for use without removal of the jacket (i.e. for use on the system pipe) are available on request. Reprotection of the field joint is not necessary in this case. This is also true for welding GEROfit®REX with jacketed pipes of other manufacturers and for welding GEROfit®REX with standard PE100/PE100-RC pipes. This operation requires appropriate tools, e.g. the jacket peeler GEROfit®pocket or pocket XL within the GEROfit® accessories programme (→ Accessories, p. 309).

Gerodur application engineers are available at all times to assist.

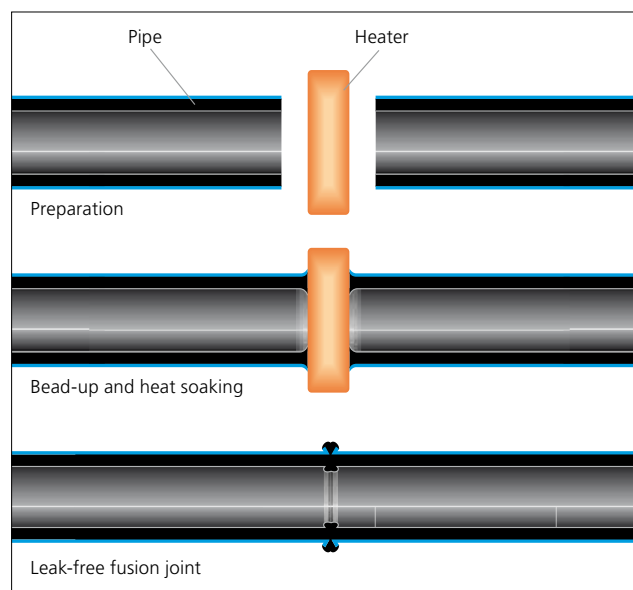

6.41 Principle of butt fusion welding

means of a re-rounding tool. End caps on the delivered pipes shall not be removed until immediately before the welding operation and then only at the ends to be welded.

All tools and pieces of equipment mentioned in the following instructions are available as Gerodur accessories (→ Accessories, p. 309). The welding report (template → p. 321) and the specified welding parameters (→ table 6.66, p. 214) shall be used to ensure proper performance of the procedure.

Work instructions according to DVS 2207-1 (HS)

1. Set up appropriate work conditions, e.g. a welding tent. → Fig. 6.43
2. Connect the welding device to the power mains or to a generating set and check its function.
3. Remove the jacket at the pipe ends for the cutback dimensions given in table 6.42, using the GEROfit®pocket or pocket XL peeler. (→ handling of jacket peelers, p. 218 et seq.) → Figs. 6.44 – 6.46.

In specific project cases, jacket removal can be done by Gerodur (to customer specifications).

DN/OD	Cutback dimension
≤280mm	35mm
>280mm	50mm

6.42 Jacket cutback dimensions

4. Place the GEROfit® film stripping gauge flush with the jacket onto the diffusion barrier layer. → Fig. 6.47
5. Carefully strip off the film with about 10 mm of film remaining under the stripping gauge. Then remove the gauge. → Figs. 6.48 + 6.50
6. Do not remove the end cap (delivered condition) from the pipe end opposite to the fusion end to avoid air draught.
7. Align and clamp the components to be welded. For pipes with a protection jacket, use appropriate inserts with a clamp size adapted to jacketed pipes. → Fig. 6.51
8. Smoothen the jointing surfaces of the pipes with a planing tool (blades must be sharp!). Then remove the tool and eliminate all shavings and chips from the welding zone. → Figs. 6.52 + 6.53

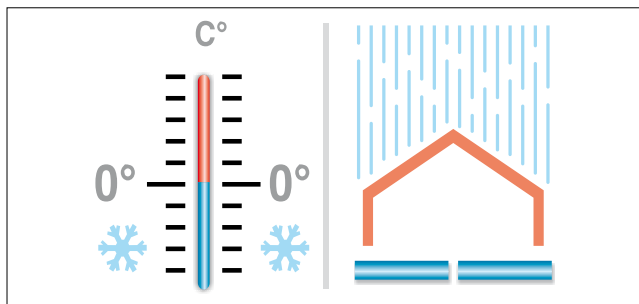

6.43 Set up and maintain appropriate work conditions

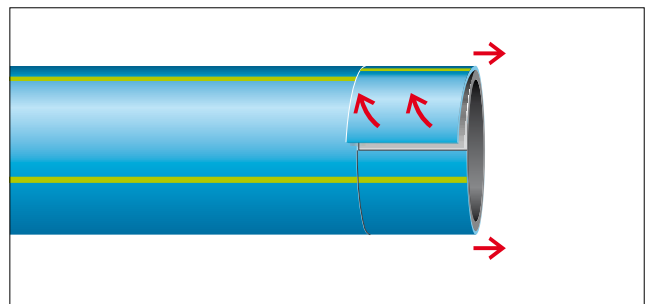

6.46 Remove the protection jacket

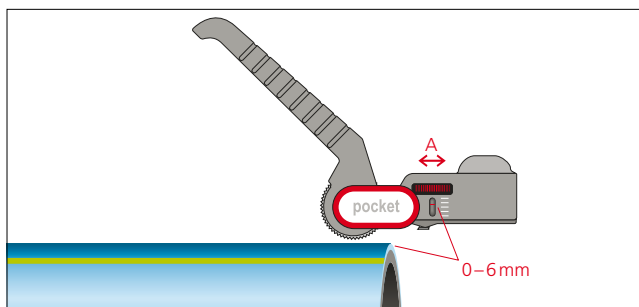

6.44 Turn the setscrew to adjust the cutting depth

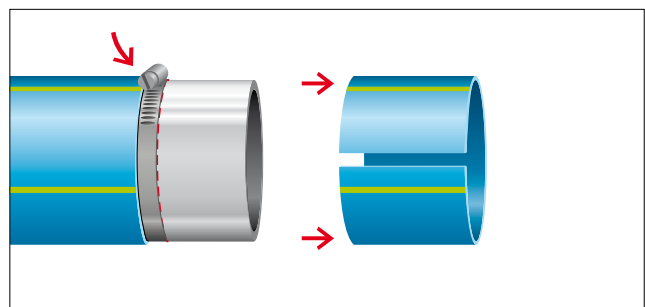

6.47 Mount a film stripping gauge flush with the jacket

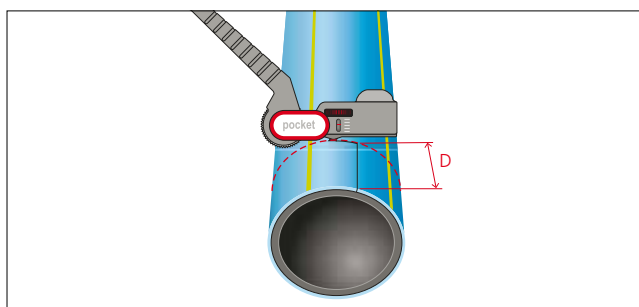

6.45 Measure the distance from the pipe end

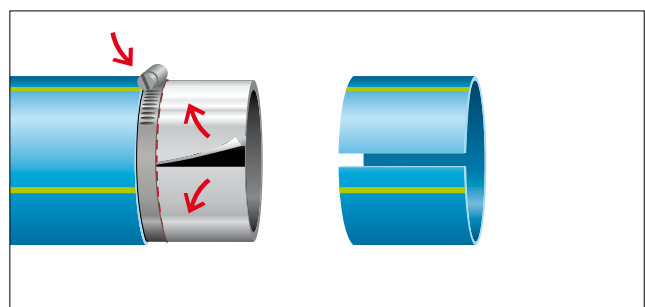

6.48 Strip off the diffusion barrier layer along the gauge edge

9. Check the planed jointing surfaces to make sure they are parallel. Check for offset (max. 0.1 x wall thickness). → Fig. 6.54
The allowable joint clearance is shown in the following table:

DN/OD	Allowable clearance
≤ 355mm	≤ 0.5mm
< 630mm	≤ 1.0mm

6.49 Allowable clearance (DVS 2207-1)

10. Check the temperature of the heater plate before starting to weld. To do so, use an instant-read instrument suitable for surface temperature measurements. Guide value for PE100: 220°C.
11. Clean the heater plate with a non-linting paper.
12. Read the drag pressure or drag force on the welding machine and record the value in the welding report.
13. Determine the settings for the bead-up and jointing pressures, or the jointing force based on the guide value of 0.15 N/mm² for PE-HD pipe. The heat-soak pressure is 0.01 N/mm².

$$\begin{aligned}
 &\text{Jointing pressure (acc. to machine parameters)} \\
 + &\text{ Drag pressure (setting)} \\
 \hline
 = &\text{ Bead-up or jointing pressure}
 \end{aligned}$$

14. All guide values (e.g. heat-soak time, jointing pressure or jointing force etc.) must be defined accordingly.
15. Where necessary, clean the fusion surfaces with an approved cleansing agent (e.g. PE cleaner) and paper in accordance with the following requirements. → Fig. 6.55

The cleansing agent, incl. the cleansing agent used for ready-made wetted cloths delivered by the manufacturer in a locking plastic box, must be composed of 100% volatilising solvent, e.g. 99 parts of ethanol with 99.8% purity and one part of MEK (methyl ethyl ketone, denaturing). Cleansing agents certified to DVGW V 603 fulfil these requirements. The safety data sheet (SDS) of the cleansing agent shall be observed. The wiping paper must be clean, first use, absorbent, unscented, non-linting and non-coloured.

16. Place the heater plate into welding position.
17. Match the fusion ends with the heater plate until sufficient bead width. → Fig. 6.56
18. Heat the fusion surfaces at reduced pressure (heat-soak time: 10 seconds per 1 mm wall thickness). Then remove the heater plate from between the jointing ends (changeover).

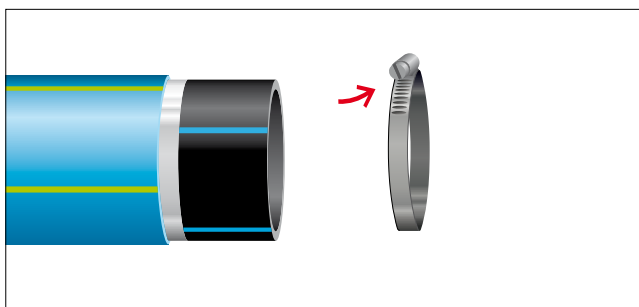

6.50 Remove the film stripping gauge

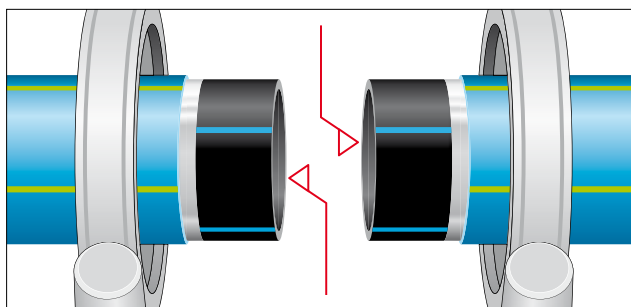

6.52 Planing

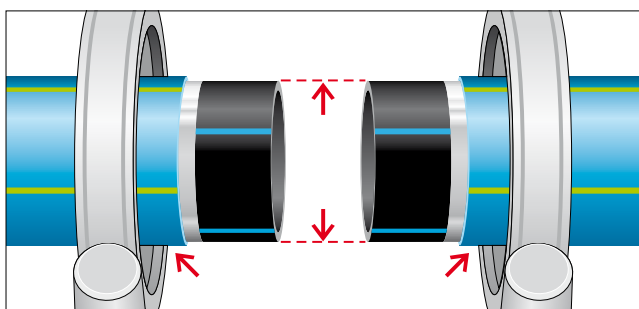

6.51 Clamp the pipes with inserts for jacketed pipes

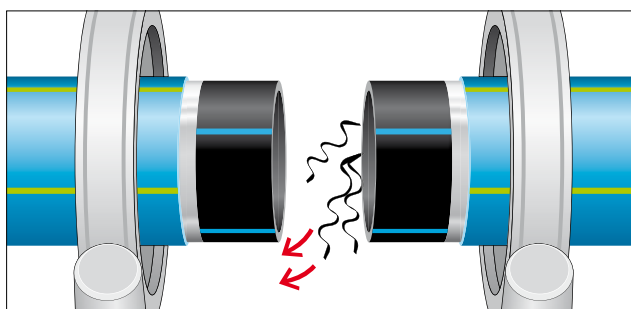

6.53 Remove chips and shavings in the jointing area

- 19. Bring together the molten ends within the changeover period (heater plate removal time). The velocity at contact must be near zero (as low as possible). Immediately join the molten ends continuously within the force build-up time until the required jointing force or required jointing pressure is reached. A proper weld will form a post-fusion bead ($K > 0$ according to DVS 2207-1). → Fig. 6.57
- 20. Maintain the jointing force until the weld has cooled down.
- 21. Remove the external weld bead with a bead removal tool. → Fig. 6.58
- 22. After the cooling phase, unclamp the jointed components and complete the welding report.
- 23. Restore the diffusion barrier layer with a GEROfit® aluminium tape, starting at one end of the exposed polymer matrix film. Wrap three layers of GEROfit® aluminium tape with 50% overlap around the exposed weld area while pressing the tape firmly onto the surface. → Fig. 6.59

24. Field joint reProtection

Variant 1

For **installations in closed construction**, the non-jacketed field joint area shall first be levelled out and then covered to protect the pipe surface from damage. For this purpose, put the previously removed and thus precisely fitting jacket section back in place and join the edges by means of a hand extruder to create a non-detachable bond. → Figs. 6.60+6.61

Variant 2

I. For **installations in open construction** a self-fusing GEROfit® sealing tape shall be applied to cover the GEROfit® aluminium tape for protection. It is recommended to wrap at least one complete layer of the GEROfit® sealing tape with 50% overlap around the weld section. → Fig. 6.62

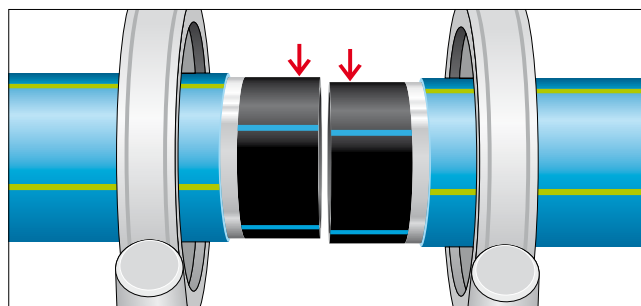

6.54 Check visually for offset and clearance

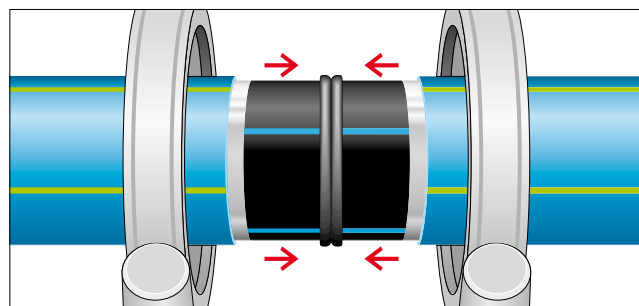

6.57 Changeover, jointing and cooling down under jointing pressure

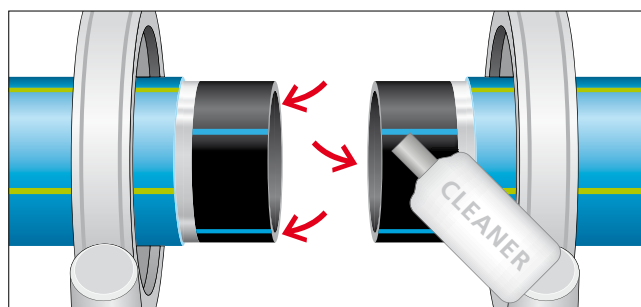

6.55 Clean the fusion surfaces with PE cleaner

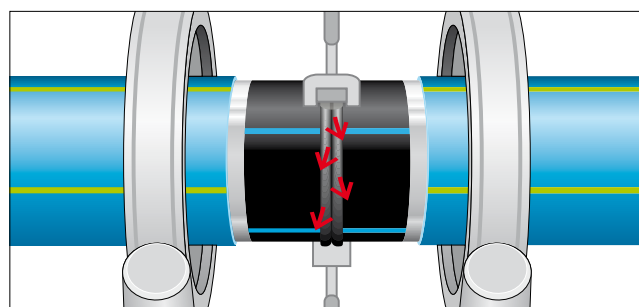

6.58 Remove the external bead with a bead removal tool

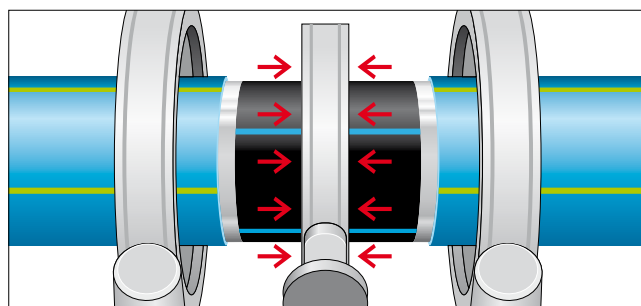

6.56 Initial bead-up and heat soaking

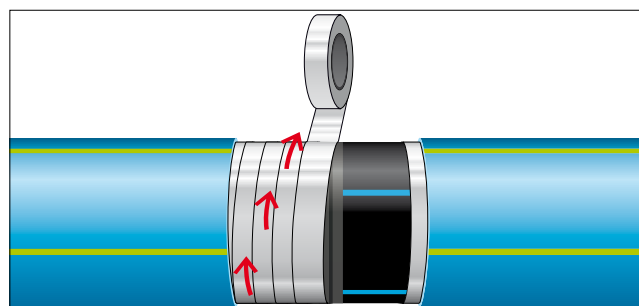

6.59 Wrap GEROfit® aluminium tape around the weld joint

- II. For **installations in closed construction** the non-jacketed field joint area shall first be filled with GEROfit® fabric tape and then covered to protect the pipe surface from mechanical damage.
- III. Unpack the water-activated GEROfit® fabric tape shortly before use and fully immerse it in water (20–24°C for 40 seconds) until its colour has entirely darkened. During immersion, the fabric tape must be pressed and squeezed several times like a sponge. → Fig. 6.63
- IV. Press the front edge of the GEROfit® fabric tape firmly on the pipe surface and start to wrap it round the pipe. It is recommended to apply at least two layers of GEROfit® fabric tape with 50% overlap and continue until the jacket thickness is reached. → Fig. 6.64
- V. The GEROfit® fabric tape will harden within 20 minutes. The field joint shall not be subjected to any mechanical load during this cure time. → Fig. 6.65

Adhesive taped should be wrapped around the outer layer to provide additional fixation of the GEROfit® fabric tape during its cure time.

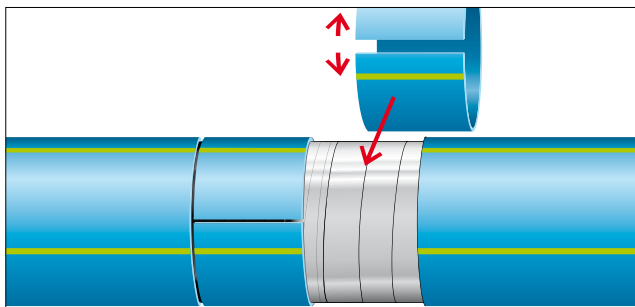

6.60 Put the previously removed jacket section back in place around the field joint (variant 1)

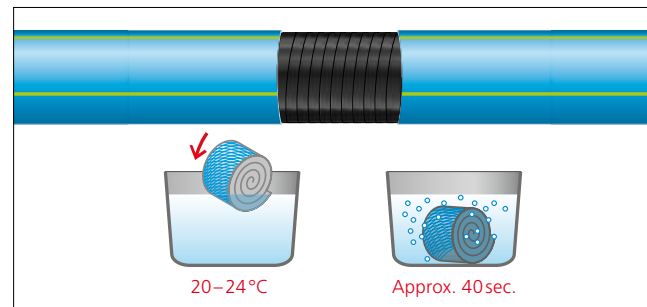

6.63 Immerse the GEROfit® fabric tape thoroughly in water (variant 2)

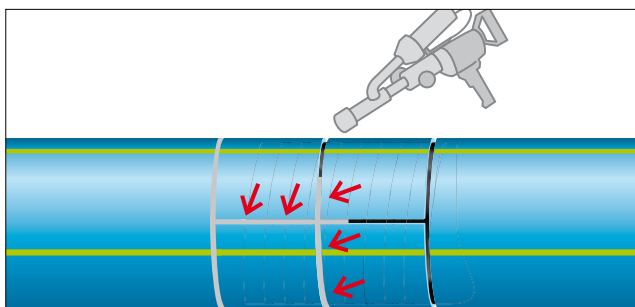

6.61 Weld the jacket piece using a hand extruder (variant 1)

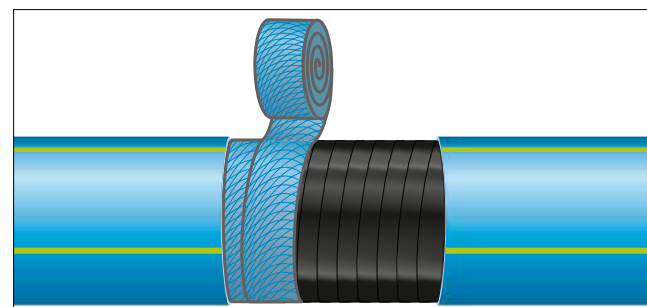

6.64 Wrap the GEROfit® fabric tape around the joint (variant 2)

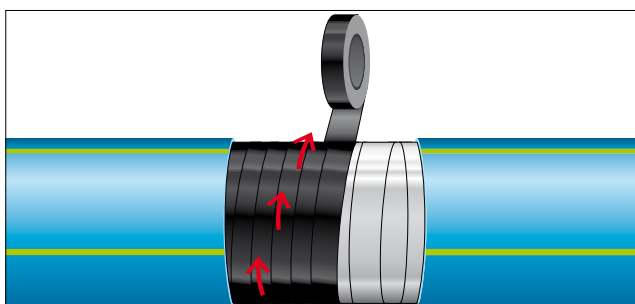

6.62 Wrap GEROfit® sealing tape around the joint (variant 2)

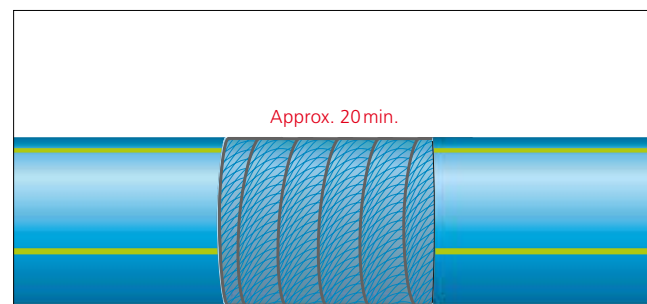

6.65 Allow the GEROfit® fabric tape to cure thoroughly (variant 2)

Nominal wall thickness	Bead-up	Heat soak	Changeover	Joining	
	Forming a specified bead size at end of initial bead-up time (minimum values) $p=0.15\text{N/mm}^2$	Heat-soak time = 10sec per 1 mm wall thickness $p\leq 0.01\text{N/mm}^2$	Heater plate removal time (maximum duration)	Joining force build-up time	Cooling time under joining pressure* (minimum values) $p=0.15\text{N/mm}^2$
[mm]	[mm]	[s]	[s]	[s]	[min]
≤4.5	0.5	≤ 45	5	5	6.5
4.5–7	1.0	45–70	5–6	5–6	6.5–9.5
7–12	1.5	70–120	6–8	6–8	9.5–15.5
12–19	2.0	120–190	8–10	8–11	15.5–24
19–26	2.5	190–260	10–12	11–14	24–32
26–37	3.0	260–370	12–16	14–19	32–45
37–50	3.5	370–500	16–20	19–25	45–61
50–70	4.0	500–700	20–25	25–35	61–85

6.66 Benchmarks for butt fusion welding according to DVS 2207-1 | * Ambient temperature of 25–40°C | Guide values applicable to GEROfit®REx pipes between 25 and 40°C and at moderate movement of the air. At lower ambient temperatures, the cooling time acc. to DVS 2207-1 can be reduced. The heater plate temperature guide value is 220°C. Changeover time must be kept as short as possible to avoid impairment of weld quality.

Electrofusion (HM)

The fusion surfaces (external surfaces of the core pipe and internal surface of the electrofusion fitting) are electrically heated via heater coils integrated in the fitting and the fitting is welded to the pipe under fusion pressure. The automatic welding operation shall be carried out with appropriate equipment adapted to the fitting. Also, the manufacturer’s information and instructions shall be observed. For GEROfit®REx the protection jacket needs to be removed by means of a suitable jacket peeling tool (GEROfit®pocket or pocket XL) over the following lengths:

Jacket removal length LS = fitting insertion depth + 15 mm (guide value)

Polymer matrix film stripping length LM = fitting insertion depth + 5 mm (guide value)

Basic conditions

The welding area shall be shielded from unfavourable weather (e.g. humidity, wind, excessive sunlight, or temperatures below 0°C). If the pipe accumulates local heat from direct sunlight, the weld area should be covered early enough to bring the temperature down. Care shall be taken to maintain the pipe and the electrofusion fitting at almost identical temperature. The mating fusion surfaces of the components to be jointed

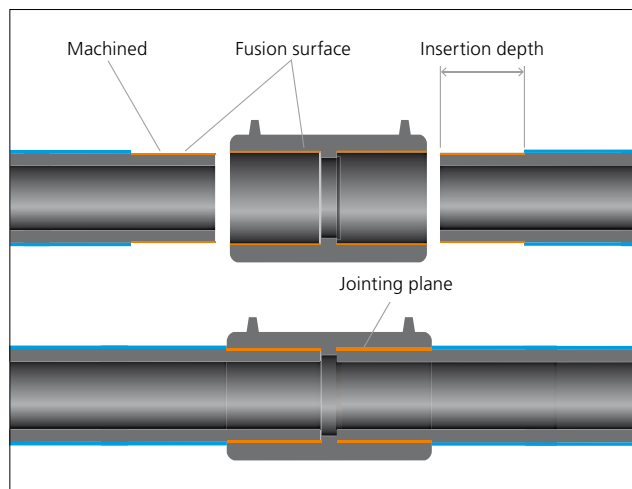

6.67 Principle of electrofusion welding

must not be damaged and must be free of contamination (e.g. dirt, grease, chips). As pipes may show ovalities after storage, it may be necessary to restore the shape of the pipe ends, e.g. by means of a re-rounding tool. End caps on the delivered pipes shall not be removed until immediately before the welding operation and then only at the ends to be welded. The mating surfaces of the pipe and electrofusion fitting shall be cleaned directly before welding.

All tools and pieces of equipment mentioned in the following instructions are available as Gerodur accessories (→ Accessories, p. 309).

An appropriate welding report (template → p. 322) shall be used to ensure proper performance of the procedure.

Work instructions according to DVS 2207-1 (HM)

1. Set up appropriate work conditions, e.g. a welding tent. → Fig. 6.68
2. Connect the welding device to the power mains or to a generating set and check its function.
3. Remove the protection jacket at the square-cut pipe ends for half the length of the fitting, using the GEROfit®pocket or pocket XL jacket peeler (→ handling of jacket peelers, p. 218 et seq.). → Figs. 6.69+6.70
4. Put the GEROfit® film stripping gauge flush with the pipe jacket onto the diffusion barrier layer. → Fig. 6.71
5. Carefully strip off the polymer matrix film with about 10 mm of film remaining under the stripping gauge. Then remove the gauge. → Figs. 6.72+6.73
6. Where necessary, use re-rounding clamps to restore the circularity of the pipe ends. Allowable ovality is 1.5 %, but no more than 3 mm.

7. Remove the oxidised layer on the pipe surface with a rotary peeling tool (hand scraper in exceptional cases only) at constant depth of about 0.2 mm. → Fig. 6.74

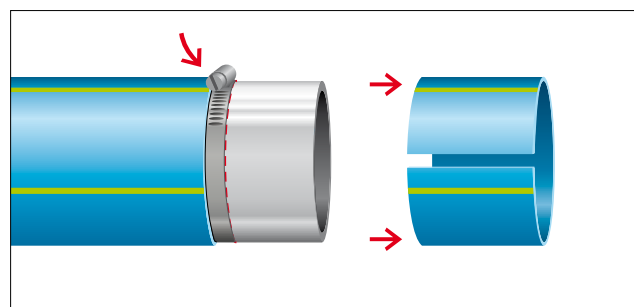

6.71 Remove the protection jacket and mount a film stripping gauge

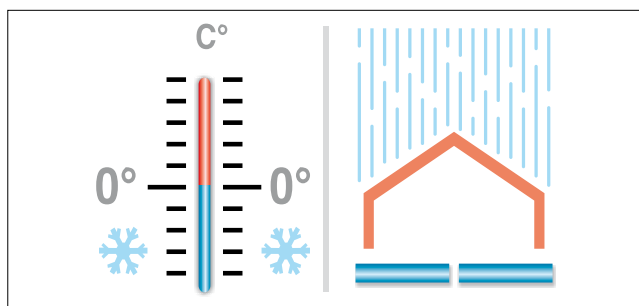

6.68 Set up and maintain appropriate work conditions

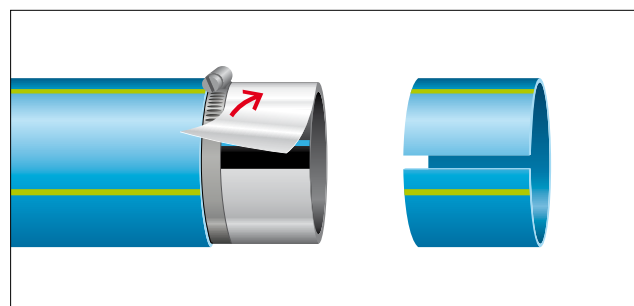

6.72 Strip off the diffusion barrier layer along the gauge edge

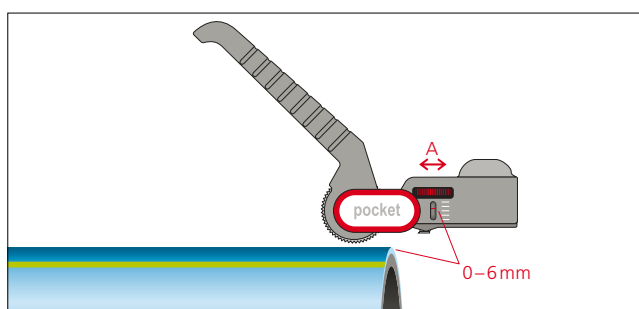

6.69 Turn the setscrew to adjust the cutting depth

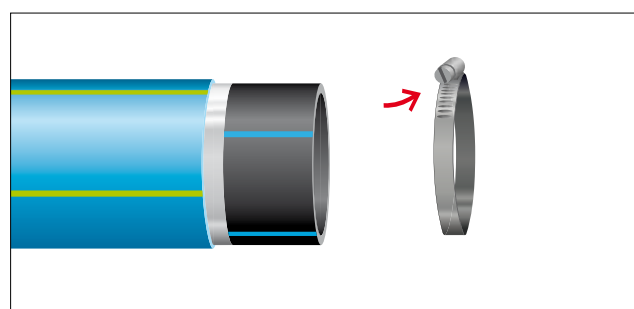

6.73 Remove the film stripping gauge

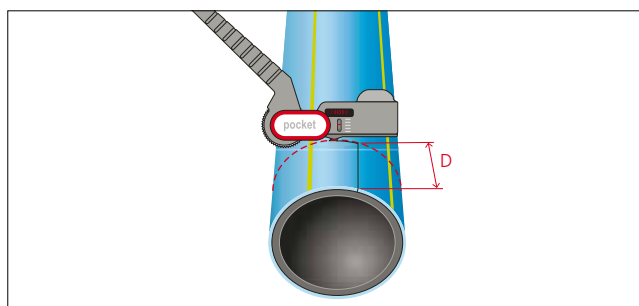

6.70 Measure the distance from the pipe end

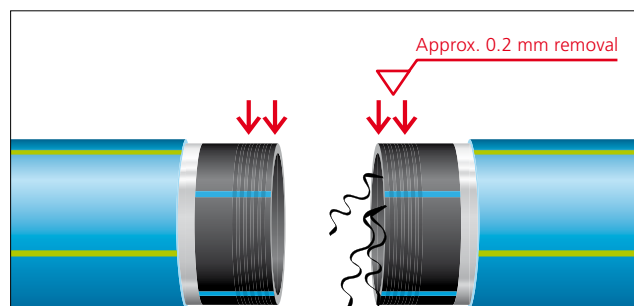

6.74 Machine the weld area, reliable with rotary peeler

8. Remove the electrofusion fitting from the original package.
9. Clean the peeled pipe surface and internal fitting surface with an approved cleansing agent (e.g. PE cleaner) and a non-linting non-coloured paper. → Fig. 6.75

The cleansing agent, incl. the cleansing agent used for ready-made wetted cloths delivered by the manufacturer in a locking plastic box, must be composed of 100% volatilising solvent, e.g. 99 parts of ethanol with 99.8% purity and one part of MEK (methyl ethyl ketone, denaturing). Cleansing agents certified to DVGW VP 603 fulfil these requirements. The safety data sheet (SDS) of the cleansing agent shall be observed. The wiping paper must be clean, first use, absorbent, unscented, non-linting and non-coloured.

10. Indicate the insertion depth with a visible mark on the pipe. We recommend a white marker pen without metal particles.

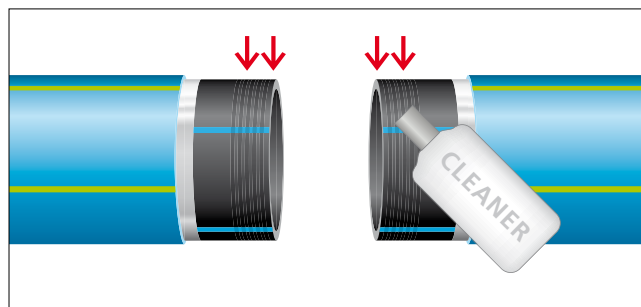

6.75 Clean the fusion surfaces with PE cleaner

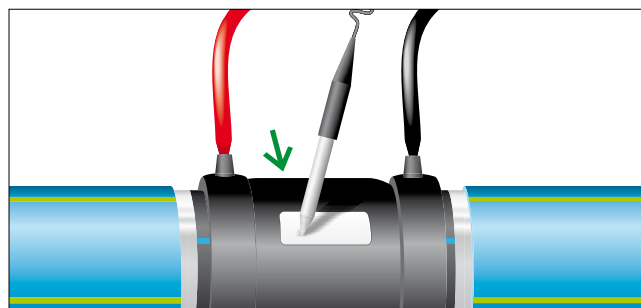

6.76 Scan the parameters (bar code), then weld and observe the cooling time

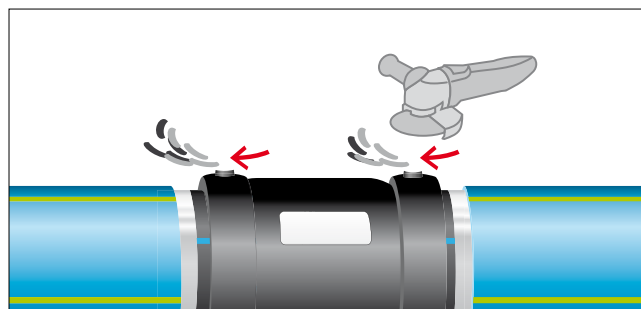

6.77 Cut off the welding contacts

11. Insert the pipe end into the fitting without applying force. Make sure the ends are square and parallel, and secure the assembly.

! Make sure the insertion depth is correct and the assembly is stressfree; use a restraining device. (The tapping clamps or weld-on saddles shall be secured on the pipe surface with a restraining device!).

12. Plug the cable of the welding machine into the fitting contacts by ensuring sufficient stress relief.
13. Check the settings or data indicated on the display as appropriate. Enter or scan the welding data into the machine. → Fig. 6.76
14. Perform or check the welding process according to the manufacturer's instructions.
15. Unplug the cable from the fitting.
16. Observe the cooling time specified by the manufacturer, then unclamp the retaining device (not required for certain tapping clamps with integrated holder – refer to the manufacturer's instructions).
17. If no automatic report is issued, draft a manual welding report.
18. Cut off the welding contacts of the electrofusion fitting. → Fig. 6.77
19. Restore the diffusion barrier by wrapping GEROfit® aluminium tape around the joint section starting at one end of the exposed polymer matrix film. Wrap at least three layers of GEROfit® aluminium tape with 50% overlap around the exposed weld area while pressing the tape firmly onto the surface. → Fig. 6.78
20. For open construction applications, apply a self-fusing GEROfit® sealing tape to protect the GEROfit® aluminium tape from damage. It is recommended to wrap at least one complete layer with 50% overlap. → Fig. 6.79

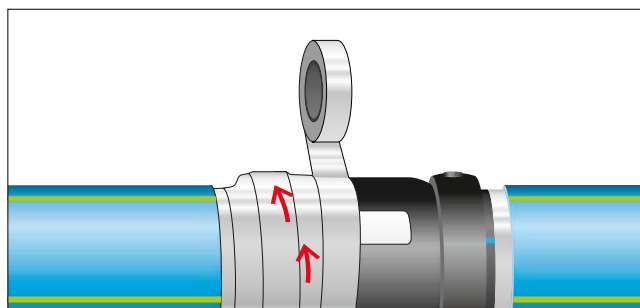

6.78 Wrap GEROfit® aluminium tape around the electrofusion fitting

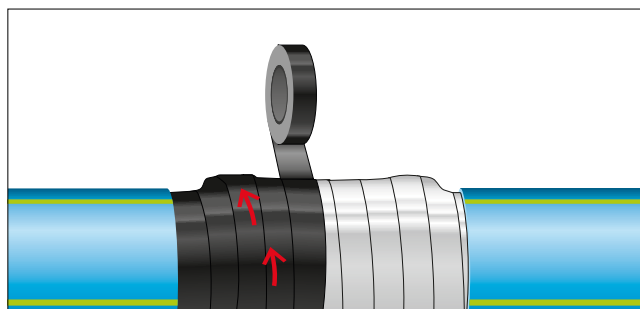

6.79 Wrap GEROfit® sealing tape around the joint

Special requirements

The following is a brief summary of special requirements applicable to butt fusion welds according to DVS 2207-1:

- The weld area must be protected from unfavourable weather impacts, such as:
 - Moisture, snow, hoarfrost, etc.
 - Ambient temperature below 0°C
 - Wind
 - Extended exposure to sunlight
- Welding at temperatures below 0°C is possible under the mentioned conditions when a sufficient pipe wall tempera-

ture is guaranteed by tenting, warming-up, heating, without impairing the manual skills of the welder.

- Under the mentioned conditions, it may be necessary to perform test welds to provide additional proof of suitability.
- A uniform temperature level shall be maintained for the pipes and fittings to be welded.
- Pipes, fittings and pipe components must have the same SDR for welding (exception: SDR 17.6 with SDR 17).

Further information

Welding operations need to be supervised according to GW 331 or DVS 2212-1 (Supplement 1). It is strongly advised to perform the welds in compliance with DVS 2207-1 and to use welding equipment meeting the requirements laid down in guideline DVS 2208-1, or to work in accordance with national guidelines conforming thereto.

It is recommended to record the welding data of the different job sections separately by nominal diameters. For welding report templates according to DVS 2207-1, → Appendix, p. 321 et seq.

Use of tapping fittings

For valve drilling fittings with sealing sleeve (system EWE for potable water) and weld-on tapping fittings, it is imperative to remove the protection jacket with the GEROfit®pocket or pocket XL jacket peeler. The welding operation shall comply with DVS 2207 (Part 1) while observing the fitting manufacturers' instructions.

Procedure

1. Mark the jacket section to be stripped on both sides according to the dimension of the tapping fitting plus 10 mm.
2. Remove the protection jacket using the GEROfit®pocket or pocket XL jacket peeler (→ handling of jacket peelers, p. 218 et seq.)
3. Mount a GEROfit® film stripping gauge to carefully strip off the film with about 10 mm of film remaining under the stripping gauge. Then remove the gauge.
4. Prepare the pipe surface and remove the oxidised layer.
5. Then the fitting can be installed.
6. Welding shall conform to DVS 2007.
7. Restore the diffusion barrier layer with GEROfit® aluminium tape, starting at one end of the exposed polymer matrix film.



6.80 Tapping fittings for manhole connection

Wrap three layers of GEROfit® aluminium tape with 50% overlap around the exposed weld area while pressing the tape firmly onto the surface.

8. When installing a tapping fitting, apply a self-fusing sealing tape to protect the GEROfit® aluminium tape from mechanical damage. It is recommended to wrap one layer of GEROfit® sealing tape with 50% overlap.

Other jointing technologies

Clamped, bolted, pressed and socket joints

Gerodur offers approved mechanical press fittings for use without removal of the jacket (i. e. for use on the system pipe). Reprotection of the field joint is not necessary in this case. Gerodur application engineers are available at all times to assist.

When using clamped, bolted, pressed or socket-type joints, it is required to remove the protection jacket according to the insertion depth. We recommend exclusive use of products approved by DVGW for PE-HD pipes. The manufacturer's instructions shall be complied with. Gerodur application engineers are available at all times to assist.

Flanged joints

Flanged connections shall be performed with corresponding stub ends (long – electrofusion, short – butt fusion).

Stub ends shall have the same SDR class as the pipes. The backing rings must match the given pressure rating. The flange manufacturer's instructions shall be complied with.



6.81 Re-rounding clamps for EF joints (source: +GF+)

PE pipes tend to flatten during storage. If ovality in the weld area is $> 1.5\%$ of the DN/OD or ≥ 3.0 mm, the pipes must be re-rounded with an appropriate tool (re-rounding clamps). The mounting instructions of the joint manufacturers must be complied with.

3.4 Handling of jacket peelers

The GEROfit®pocket and pocket XL jacket peelers are specially adapted to strip off dimensionally added and peelable protection jackets from PE pipes. Jacket removal procedures vary depending on products or manufacturers. The present instructions are solely focused on the peeler tool. For a detailed description of the individual work steps and particularities of a specific pipe, it is imperative to consult and observe the separate instructions of the pipe manufacturer and, where necessary, fitting manufacturer.

The peeler can be used both in industrial shops and on construction sites. The work area must always be kept clean. Chips, shavings or dirt can impair the function of the tool. The peeling knife and the moving parts shall be cleaned as described herein; oil the tool as appropriate (precision engineering oil).

Important:

All work must conform to currently applicable safety rules to ensure personal safety both for oneself and other persons. Improper use can cause injuries or damage the product/pipe in a way to reduce its service life or even destroy it.

Gerodur jacket peelers are available in two sizes (→ Accessories, p. 309):

GEROfit®pocket jacket peeler

DN/OD 32 – 160 mm

GEROfit®pocket XL jacket peeler

DN/OD 160 – 630 mm

There is no difference in handling.

The stripping width or cutback dimension (D) of the zone to be peeled off shall be selected according to the dimensional data provided by the manufacturer of the fitting.

The tool is not suitable for other uses like opening tin cans – very high risk of injury!

We recommend that the peeler should be kept in the original tool box or bag after usage.

Peeling for Type 3 jacketed pipe acc. to PAS 1075*At end of pipe*

1. Use the setscrew (A) to adjust the cutting depth to the given jacket thickness (0–6 mm). → Fig. 6.82

! A cutting depth setting in excess of the jacket thickness can damage the core pipe or the diffusion barrier.

2. Mark the stripping width (D) before starting to cut. → Fig. 6.83
3. Move the lever (B) while holding down the toothed wheel to slit the protection jacket open. Each time when starting a lengthwise (axial) or circular (radial) cut, guide the

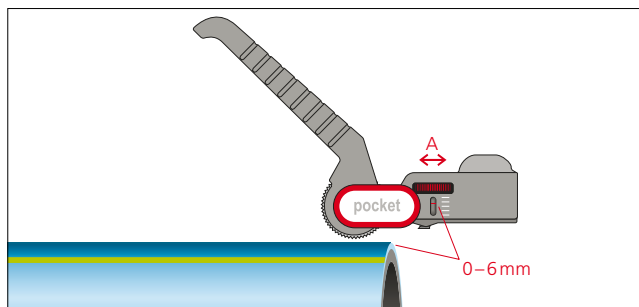

6.82 Adjust the cutting depth with the setscrew (A).

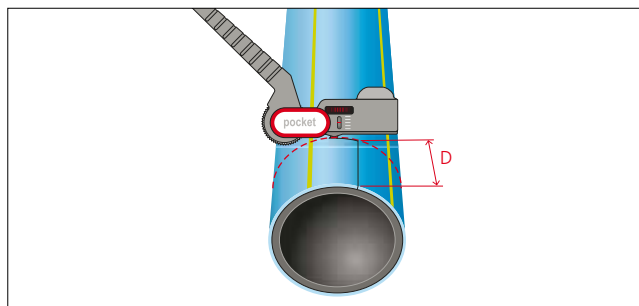

6.83 Measure the distance from the pipe end

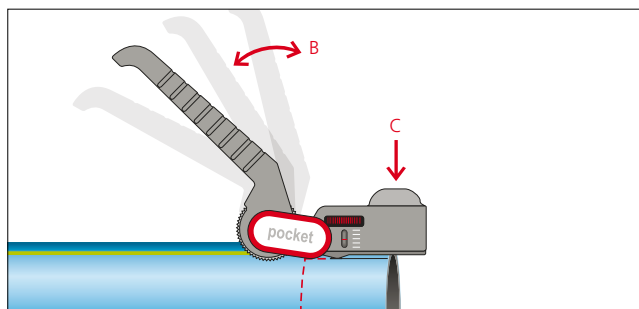

6.84 Lengthwise cut along the pipe axis

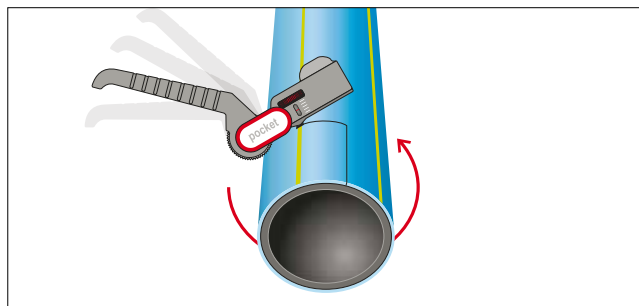

6.85 Radial cut in parallel with the pipe end

knife by pressing it slightly down with your finger (C). → Fig. 6.84

4. The peeler can be turned by 90 degrees between a lengthwise (axial) cut and a circular (radial) cut. → Fig. 6.85
5. After cutting, the jacket can be easily removed (for larger pipe sizes it may be necessary to use pliers for stripping off the jacket). → Fig. 6.86
6. Check for integrity of the pipe surface.

Between pipe ends

(same settings as described above)

7. Mark the dimensions of the jacket section to be cut out (e.g. with an indelible marker).
8. Press the tip of the cutting knife into the pipe jacket to cut out an "intermediate length" (e.g. for saddle). → Fig. 6.87

! Before proceeding to the next operation, check the surface of the core pipe. Damaged pipe sections must be cut off.

Spare knife/knife change

The knife can be changed by turning (opening/closing) the setscrew (A). → Fig. 6.88

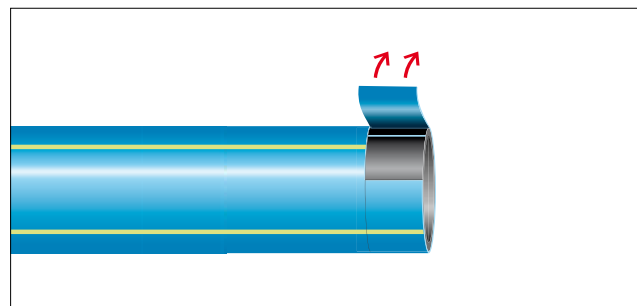

6.86 Strip off the jacket

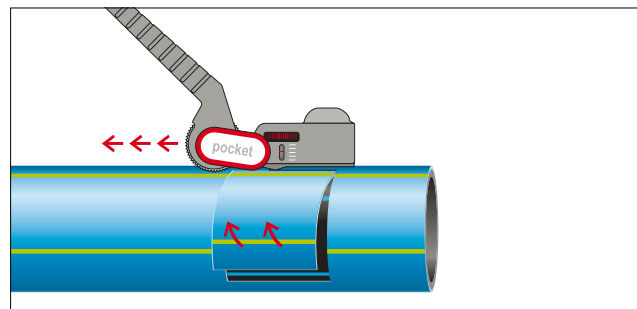

6.87 Cut and strip off the jacket between pipe ends

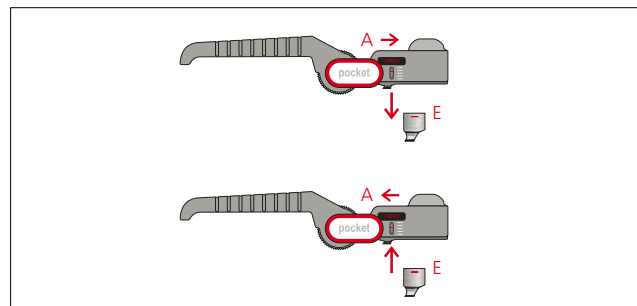

6.88 How to replace the knife